

# Polyblend® Polymer Feed System PB Series (Large Frame)

The Polyblend® PB Series liquid polymer feed system is the most popular polymer feed system offered with over 10,000 units in service worldwide. The Polyblend® PB Series System combines years of technical expertise with simple operation to provide an inexpensive means to maximize polymer activation.

The compact design of the Polyblend® PB Series System provides easy installation. The corrosion-resistant, stainless-steel chassis houses the lightweight, portable system, allowing for easy mobility. The simple-to-use electronic controls and adjustable flow meter permit precise water control for a variety of solution concentrations. In addition, the PB1000 Series is designed with a secondary flow meter and static mixer for additional post-dilution.

At the center of the Polyblend® PB Series polymer feed system is the U.S. patented multi-zone mixing chamber. The advanced design provides uniform dispersion energy at the moment of initial wetting. The high energy mix prevents agglomerations and eliminates the need for extended mixing and aging by applying the right energy at the right time. The low energy zone continues to activate the hydrated polymer without destroying the fragile polymer chains. The result is maximum polymer activation and improved polymer performance.



## Key Benefits

- *Trusted and proven technology providing maximum polymer activation*
- *Simple electronic controls for easy operation*
- *Compact design with a minimal footprint*

Model	Water Flow Rate LPH / (GPH)	Diaphragm Pump Output LPH / (GPH)
PB600-1	227-2270 / 60-600	0.04-3.78 / (0.01-1.0)
PB600-2	227-2270 / 60-600	0.08-7.57 / (0.02-2)
PB600-4.5	227-2270 / 60-600	0.17-17 / (0.045-4.5)
PB600-8	227-2270 / 60-600	0.3-30.2 / (0.08-8)
PB1000-1	227-4542 / 60-1200	0.04-3.78 / (0.01-1.0)
PB1000-2	227-4542 / 60-1200	0.08-7.57 / (0.02-2)
PB1000-4.5	227-4542 / 60-1200	0.14-17 / (0.045-4.5)
PB1000-8	227-4542 / 60-1200	0.3-30.2 / (0.08-8)

### PB600 Standard Layout

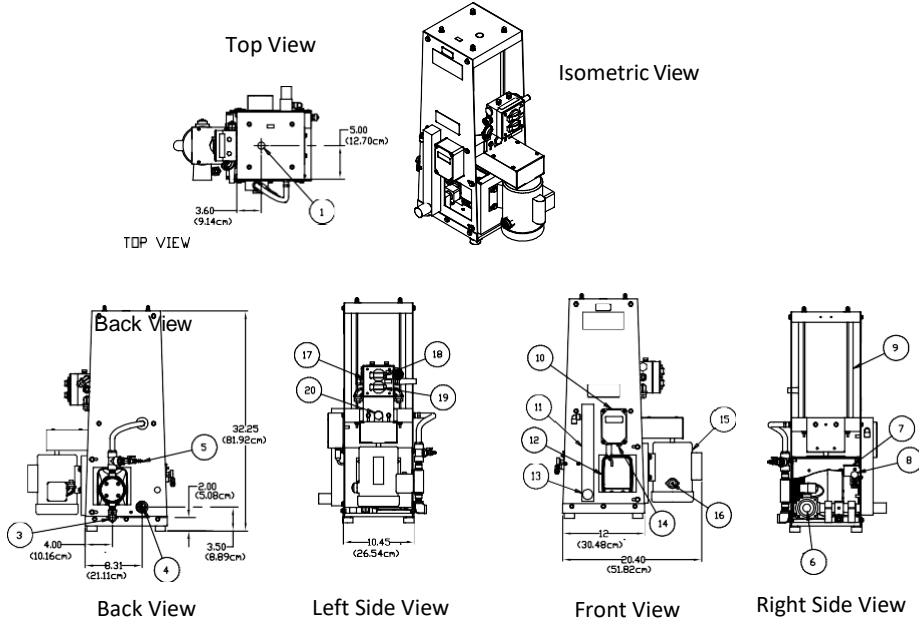

Key	Description
1	Discharge, 1" (F)NPT (25.4 mm)
2	Power Cord
3	Polymer Inlet, 5/8" O.D.Barb (15.9 mm)
4	Water Inlet, 1" (F)NPT (25.4 mm)
5	Priming Port (Pump)
6	Solenoid Valve, (Water)
7	Differential Pressure Switch
8	Delta P Adjustment Screw
9	Mix Chamber
10	Digital Display Pump Controller (REM-1E)
11	Rotameter
12	Diaphragm Pump
13	Rate Valve
14	4-20mA Input
15	Mixer Motor
16	Manual Reset Thermal Protector
17	Junction Box
18	Main Power Switch
19	Mixer Motor Switch
20	Auxiliary Port

### PB1000 Standard Layout

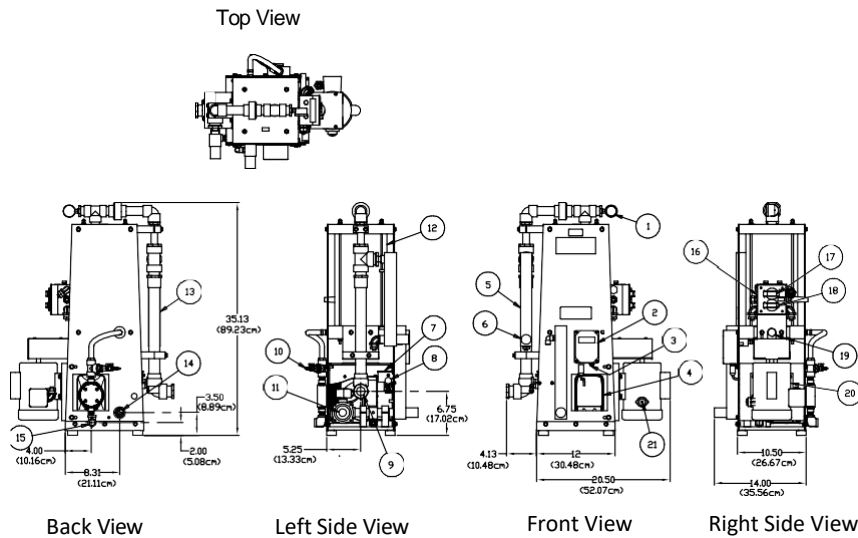

Key	Description
1	Pressure Gauge
2	Digital Display Pump Controller (REM-1E)
3	4-20ma Input
4	Pump, Diaphragm
5	Rotameter
6	Rate Valve
7	Differential Pressure Switch
8	Delta P Adjustment Switch
9	Solution Discharge, 1" (F)NPT (25.4mm)
10	Pump Priming Port
11	Solenoid Valve, Water
12	Mix Chamber
13	Static Mixer
14	Water Inlet, 1"(F)NPT (25.4mm)
15	Polymer Inlet, 1/2" (F)NPT (12.7 mm)
16	Junction Box
17	Main Power Switch
18	Mixer Motor Switch
19	Auxiliary Port
20	Mixer Motor
21	Manual Reset Thermal Protector
22	Power Cord (Not Shown)

**cleanwater1**

1901 West Garden Road | Vineland, NJ 08360

Tel: 856.896.2160

Email: [info@cleanwater1.com](mailto:info@cleanwater1.com)

**cleanwater1.com**

© 2023 Cleanwater1, Inc. Subject to change without prior notice.

The information provided in this literature contains merely general descriptions or characteristics of performance which in actual case of use do not always apply as described or which may change as a result of further development of the products. An obligation to provide the respective characteristics shall only exist if expressly agreed in the terms of a written contract.