

**Series 55-200 Armored Flowmeter**  
**With Magnetic Indicator with**  
**Varea-Com™ Electronic Transmitter FM Approved**

**UGSI CHEMICAL FEED**

A cleanwater1 Company

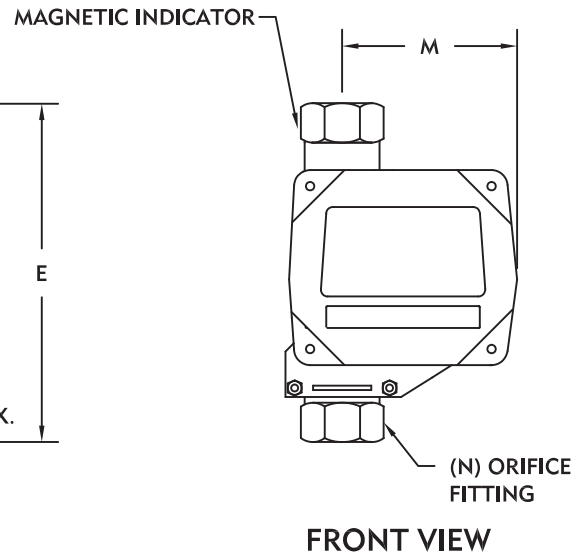
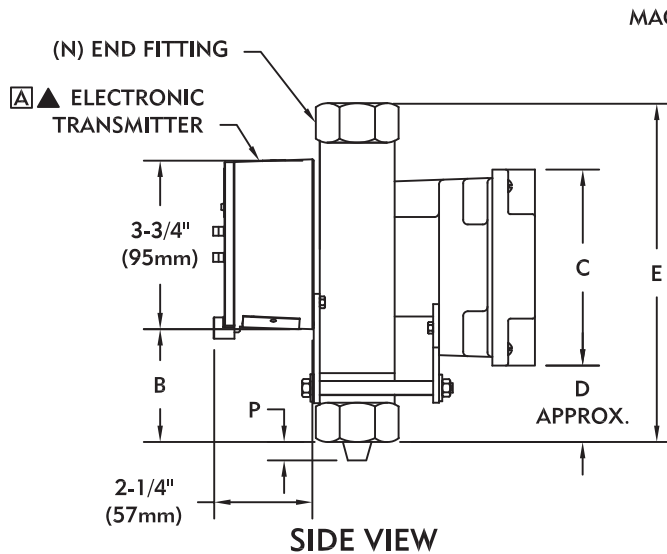
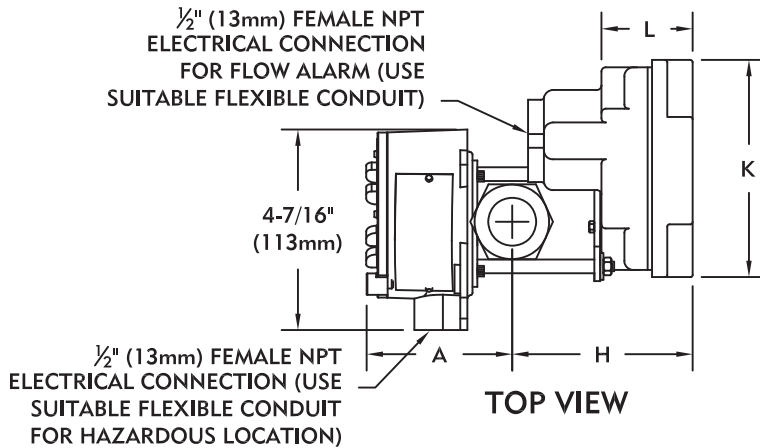

TUBE SIZE	A	B	C	D	E	H	K	L	M	N	P
1/2" (13mm)	2-1/16" (68mm)	2-3/8" (54mm)	5" (127mm)	1-3/16" (46mm)	7-1/2" (191mm)	4-3/16" (106mm)	5-7/8" (149mm)	2-3/4" (57mm)	3-3/4" (95mm)	1/2" NPT	—
1" (25mm)	3-1/16" (78mm)	2-7/8" (73mm)	5" (127mm)	2" (51mm)	8-13/16" (227mm)	4-1/2" (114mm)	5-7/8" (149mm)	2-3/4" (57mm)	4-3/16" (110mm)	1" NPT	3/16" (8mm)
1-1/2" (38mm)	3-3/16" (90mm)	4-1/8" (105mm)	5" (127mm)	2-3/4" (70mm)	11-3/8" (295mm)	5" (127mm)	5-7/8" (149mm)	2-3/4" (57mm)	4-9/16" (116mm)	1-1/2" NPT	1" (25mm)
2" (51mm)	4" (102mm)	4-3/4" (121mm)	5" (127mm)	3" (76mm)	12-7/8" (327mm)	5-7/16" (138mm)	5-7/8" (149mm)	2-3/4" (57mm)	5" (127mm)	2" NPT	1-3/8" (35mm)

**NOTES:**

- ▲ ACCESSORY ITEM FURNISHED ONLY IF SPECIFICALLY LISTED IN QUOTATION AND AS CHECKED ON THIS DRAWING.
- ▲ FM APPROVED EXPLOSION PROOF FOR CLASS I, DIV I, GROUPS A, B, C, & D HAZARDOUS LOCATION AND DUST IGNITION PROOF FOR CLASS II, DIV I, GROUPS E, F, & G HAZARDOUS LOCATION; SUITABLE FOR CLASS III, DIV I WITH APPROVED BARRIER.

**UGSI Chemical Feed, Inc.**  
 a Cleanwater1 company

Vineland, NJ 08360  
 856.896.2160 phone

info@cleanwater1.com  
 www.cleanwater1.com

Dimensions  
 CF.550.200.106.CN.0723