

**Series 55-200 Armored Flowmeter
Magnetic Indicator with
General Purpose Flow Switch**

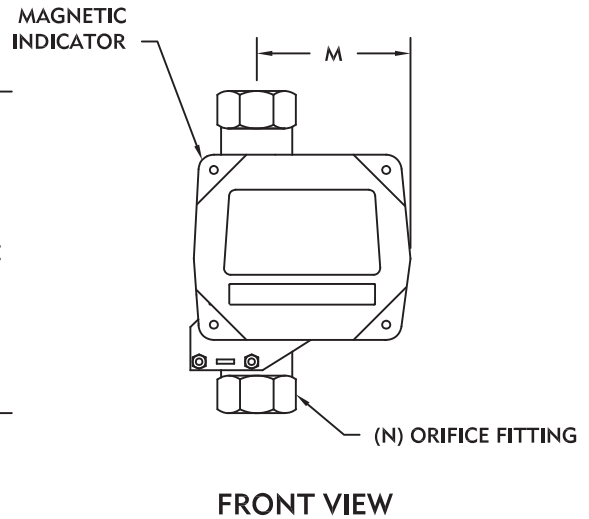
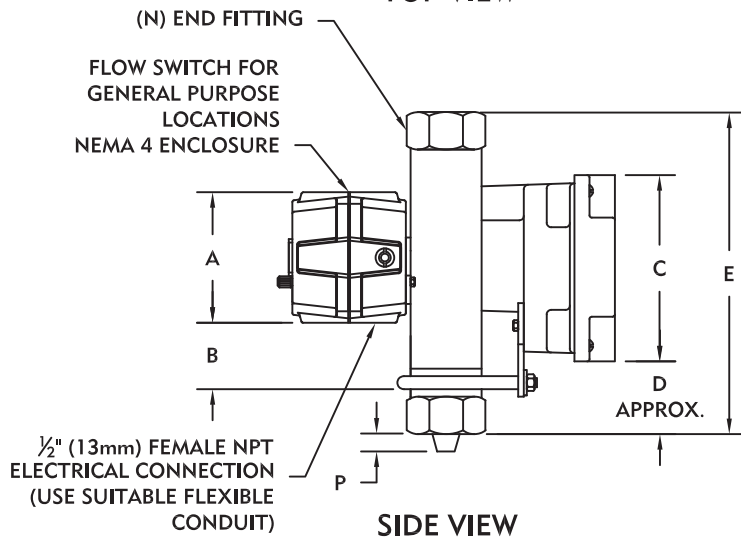
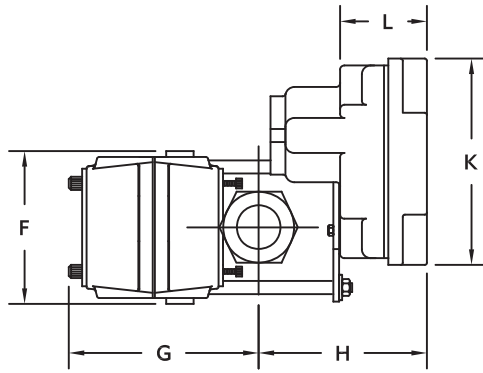

| TUBE SIZE | A | B | C | D | E | F | G | H | K | L | M | N | P |
|---------------|------------|----------------|------------|-----------------|------------------|----------------|------------------|-----------------|----------------|---------------|-----------------|------------|---------------|
| 1/2" (13mm) | 4" (102mm) | 2" (51mm) | 5" (127mm) | 1-13/16" (46mm) | 7-1/2" (191mm) | 4-3/8" (111mm) | 4-15/16" (125mm) | 4-3/16" (106mm) | 5-7/8" (149mm) | 2-1/4" (57mm) | 3-3/4" (95mm) | 1/2" NPT | --- |
| 1" (25mm) | 4" (102mm) | 2-3/16" (56mm) | 5" (127mm) | 2" (51mm) | 8-15/16" (227mm) | 4-3/8" (111mm) | 5-1/4" (133mm) | 4-1/2" (114mm) | 5-7/8" (149mm) | 2-1/4" (57mm) | 4-3/16" (110mm) | 1" NPT | 5/16" (8mm) |
| 1-1/2" (38mm) | 4" (102mm) | 3" (76mm) | 5" (127mm) | 2-3/4" (70mm) | 11-5/8" (295mm) | 4-3/8" (111mm) | 5-3/4" (146mm) | 5" (127mm) | 5-7/8" (149mm) | 2-1/4" (57mm) | 4-9/16" (116mm) | 1-1/2" NPT | 1" (25mm) |
| 2" (51mm) | 4" (102mm) | 3" (76mm) | 5" (127mm) | 3" (76mm) | 12-7/8" (327mm) | 4-3/8" (111mm) | 6-3/16" (157mm) | 5-7/16" (138mm) | 5-7/8" (149mm) | 2-1/4" (57mm) | 5" (127mm) | 2" NPT | 1-3/8" (35mm) |

UGSI Chemical Feed, Inc.
a Cleanwater1 company

Vineland, NJ 08360
856.896.2160 phone

info@cleanwater1.com
www.cleanwater1.com

Dimensions
CF.550.200.102.CN.0723