

# Straight Through Metal Tube Varea-Meter® Unit

With Magnetic Indicator with  
External Flow Switch for Use in Hazardous Locations

**UGSI CHEMICAL FEED**

A Cleanwater1 Company

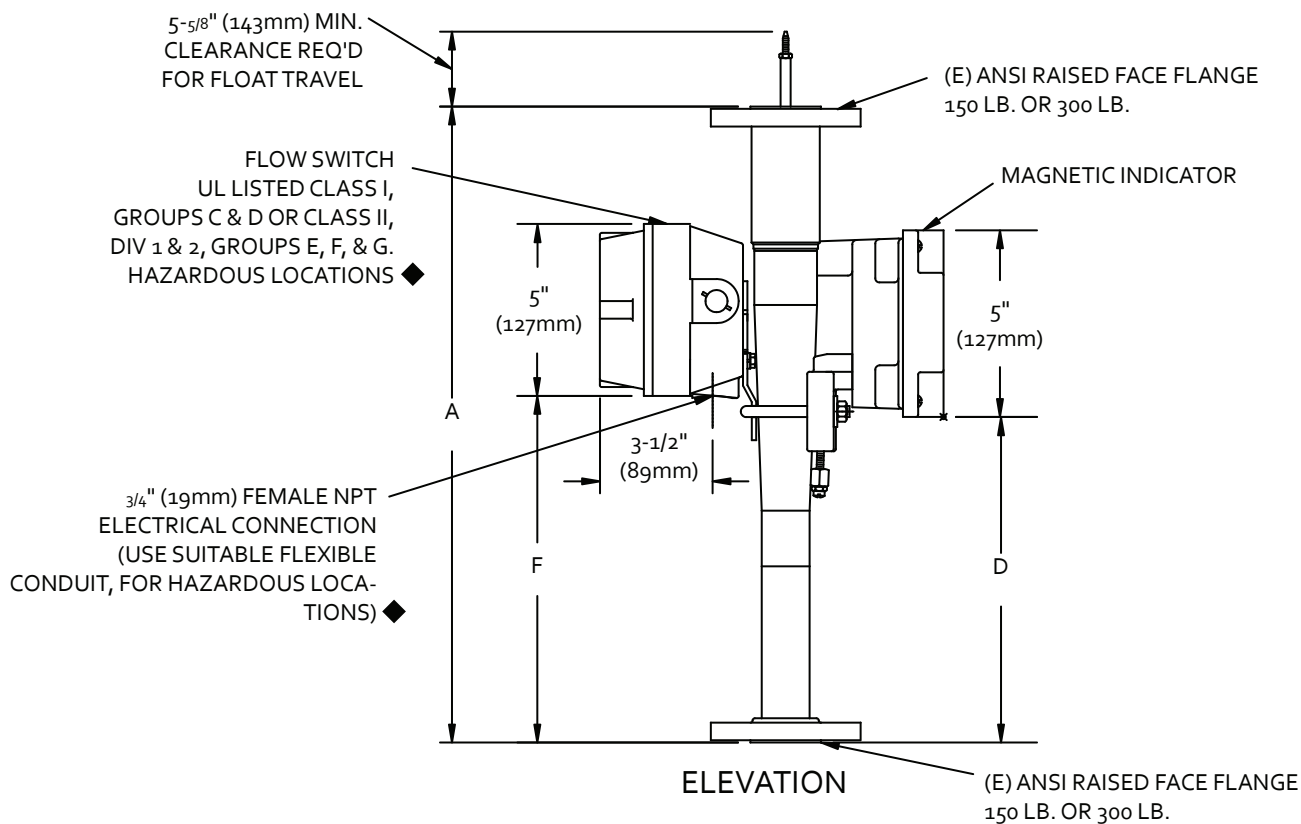
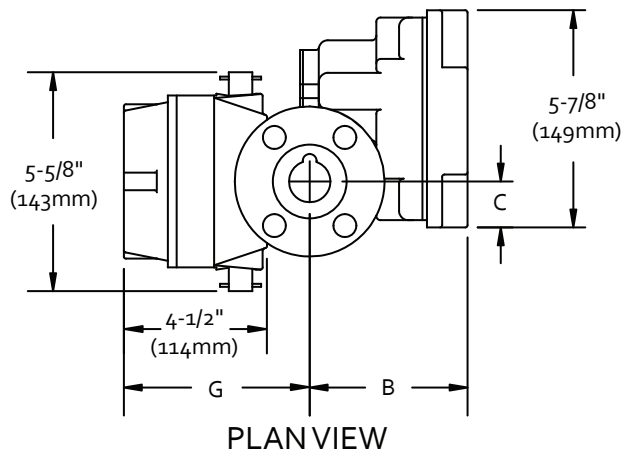

◆ AS DEFINED BY NEC.

**UGSI Chemical Feed, Inc.**  
a Cleanwater1 company

Vineland, NJ 08360  
856.896.2160 phone

info@cleanwater1.com  
www.cleanwater1.com

Dimensions  
CF.520.205.106.CN.0723