

**Straight Through Metal Tube
Varea-Meter® Unit
With Magnetic Indicator with
General Purpose External Flow Switch**

UGSI CHEMICAL FEED

A cleanwater1 Company

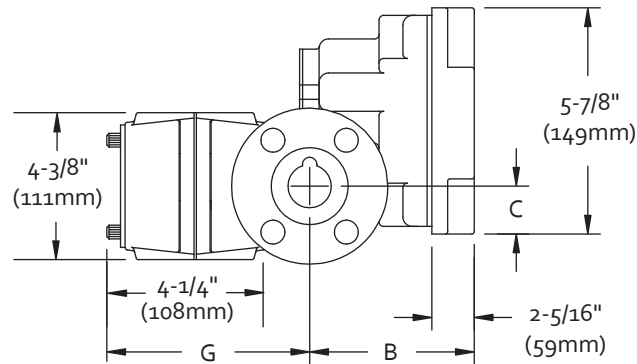

PLAN VIEW

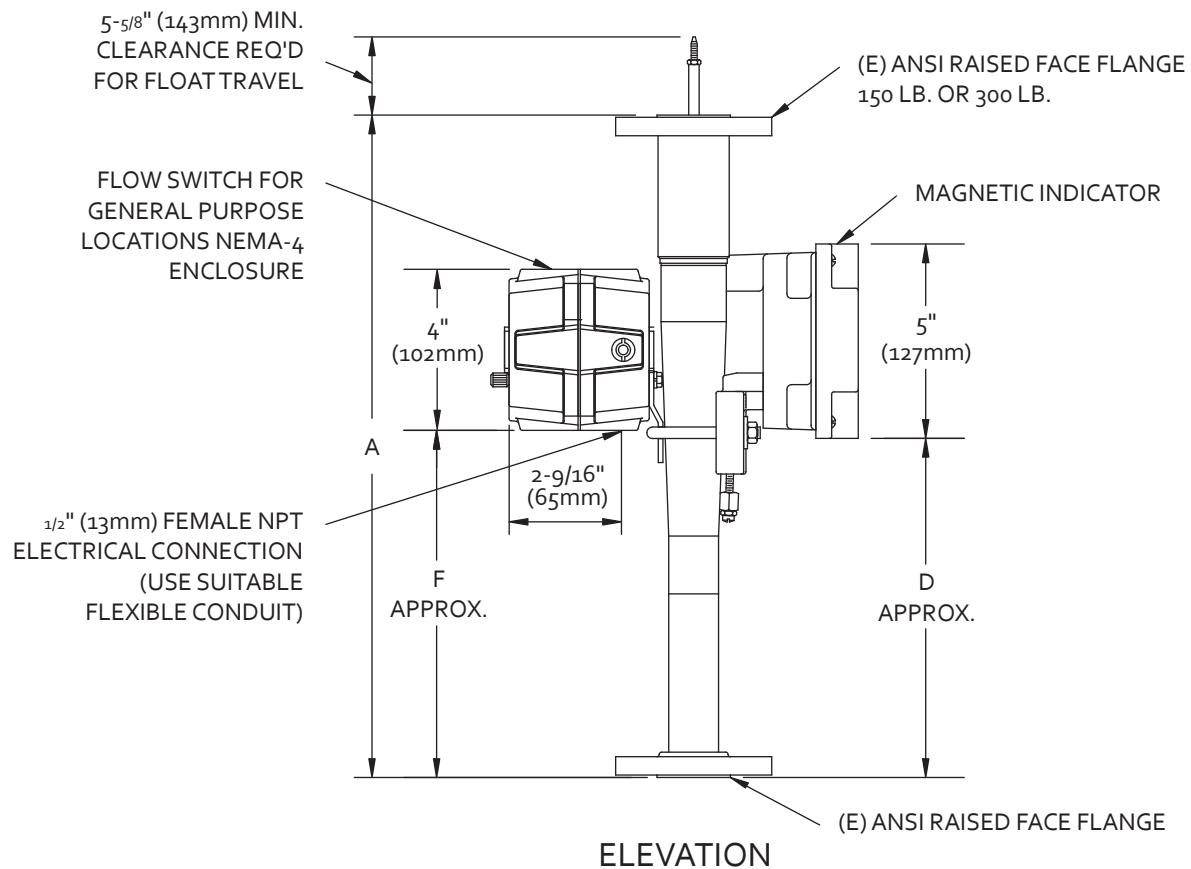

UGSI Chemical Feed, Inc.
a Cleanwater1 company

Vineland, NJ 08360
856.896.2160 phone

info@cleanwater1.com
www.cleanwater1.com

Dimensions
CF.520.205.104.CN.0723