

**Straight Through Metal Tube
Varea-Meter® Unit
With Magnetic Indicator**

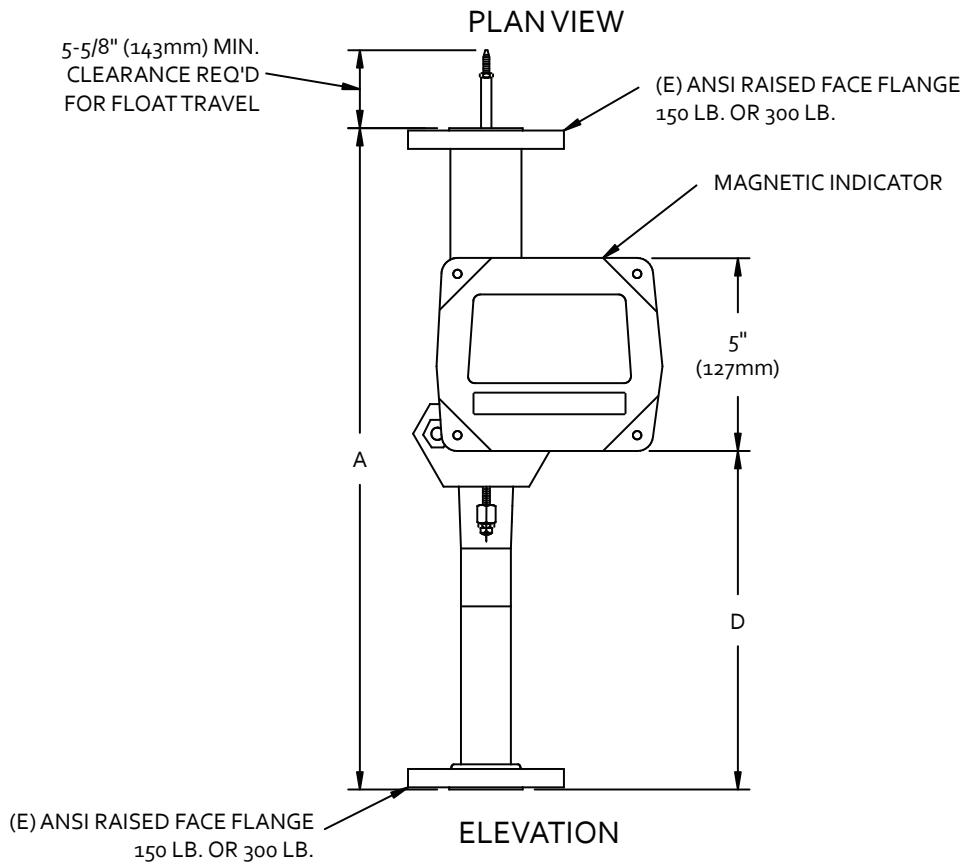
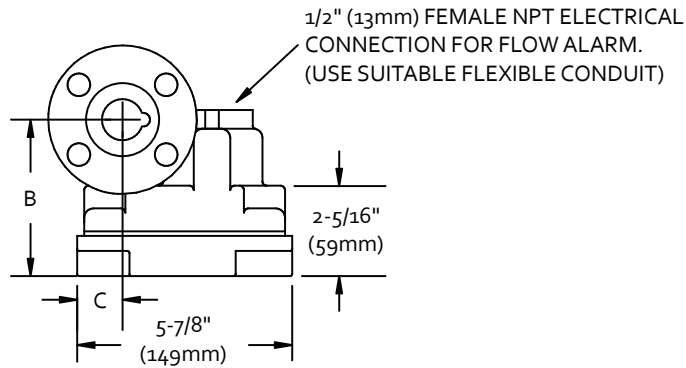

NOTES:

ACCESSORY ITEM FURNISHED ONLY IF SPECIFICALLY LISTED ON QUOTATION AND AS CHECKED ON THIS DRAWING.

WHEN INSTALLED WITH APPROVED BARRIER.

METER SIZE	A	B	C	D	E	F	G
1/2" (13mm)	18" (457mm)	3-3/16" (90mm)	1-3/16" (40mm)	9-3/16" (233mm)	1" (25mm)	10" (254mm)	3-3/4" (83mm)
3/4" (19mm)	18" (457mm)	4-3/16" (106mm)	1-5/16" (33mm)	9-7/16" (240mm)	1" (25mm)	10-1/2" (267mm)	3-5/8" (86mm)
1" (25mm)	18" (457mm)	4-3/16" (106mm)	1-5/16" (33mm)	9-7/16" (240mm)	1" (25mm)	10-3/4" (260mm)	3-5/8" (92mm)
1-1/2" (38mm)	20" (508mm)	4-3/4" (121mm)	1-3/16" (30mm)	10-1/8" (251mm)	1-1/2" (38mm)	10-3/2" (267mm)	4" (102mm)
2" (51mm)	20" (508mm)	5-7/16" (138mm)	1-1/8" (17mm)	9-3/4" (248mm)	2" (51mm)	9-7/8" (251mm)	4-3/8" (111mm)

UGSI Chemical Feed, Inc.
a Cleanwater1 company

Vineland, NJ 08360
856.896.2160 phone

info@cleanwater1.com
www.cleanwater1.com

Dimensions
CF.520.205.100.CN.0723