

Glass Tube Varea-Meter® Unit
Mounting on Front of Panel

UGSI CHEMICAL FEED

A cleanwater1 Company

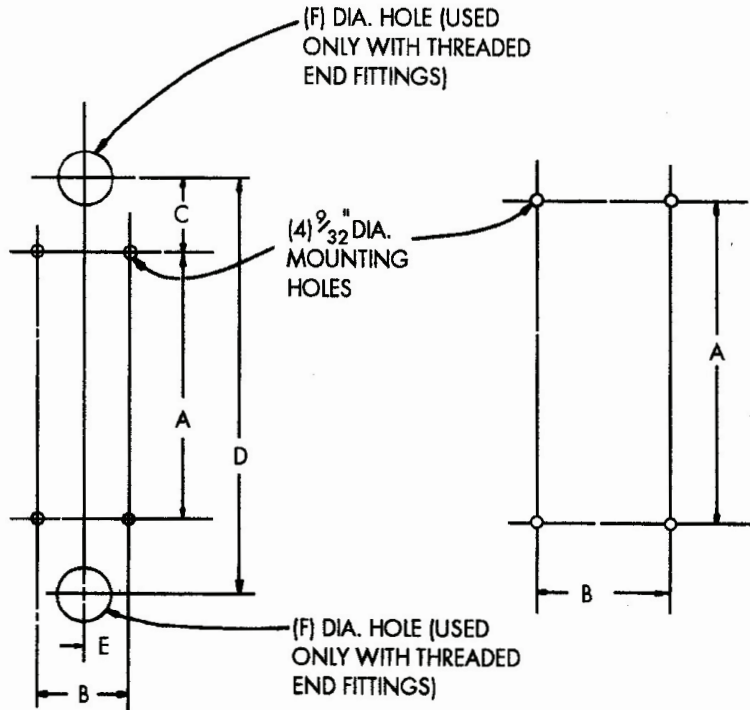

3/8", 1/2", 3/4", 1" & 1 1/2" SIZES

2" SIZE

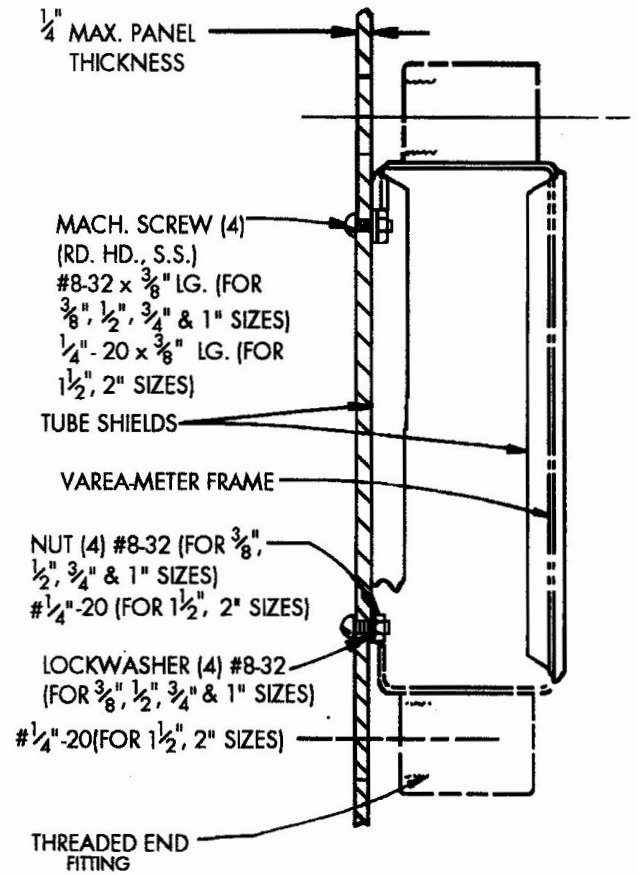

TUBE SIZE	SCALE LENGTH	A	B	C	D	E	F
3/8", 1/2"	5"	7-7/8"	2-1/16"	1-13/16"	11-1/2"	1-1/32"	15/16"
	10"	12-7/8"			16-1/2"		
3/4"	5"	7-7/8"	2-1/16"	2-5/16"	12-1/2"	1-1/32"	1-1/8"
	10"	12-7/8"			17-1/2"		
1"	5"	9-15/16"	2-9/16"	1-9/32"	12-1/2"	1-9/32"	1-3/8"
	10"	14-15/16"			17-1/2"		
1-1/2"	5"	9-9/16"	3-1/2"	2-31/32"	15-1/2"	1-3/4"	2"
	10"	14-9/16"			20-1/2"		
2"	5"	9-13/16"	3-1/2"	3-3/32"	16"	1-3/4"	2-1/2"
	10"	14-13/16"			21"		

UGSI Chemical Feed, Inc.
 a Cleanwater1 company

Vineland, NJ 08360
 856.896.2160 phone

info@cleanwater1.com
 www.cleanwater1.com

Dimensions
 CF.520.100.102.CN.0723