

**Arma-View® II Low Flow  
Armored Purge Meter  
With Explosion Proof Transmitter**

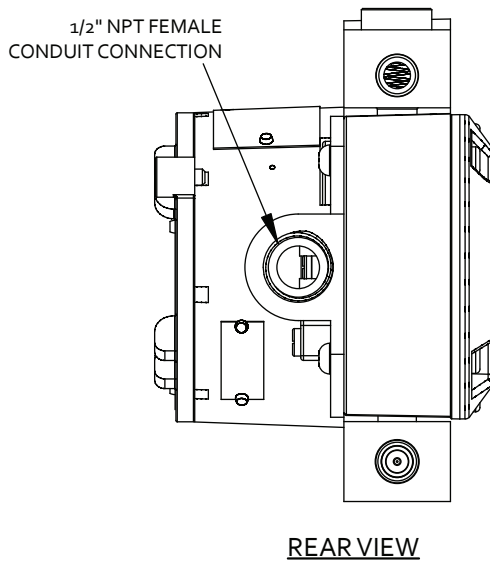
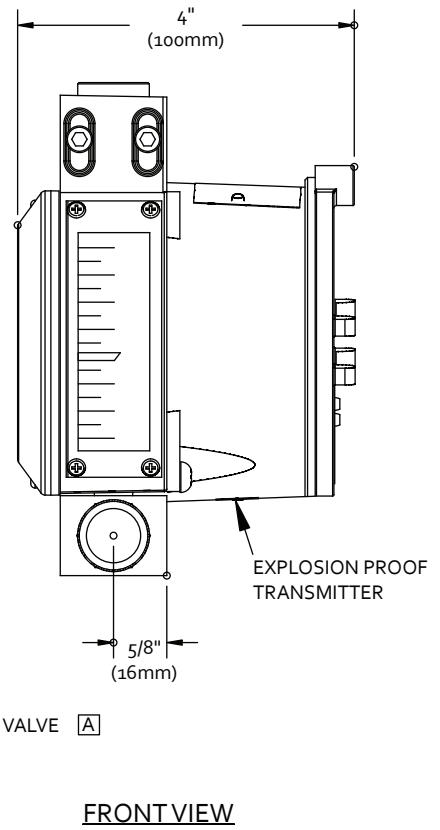
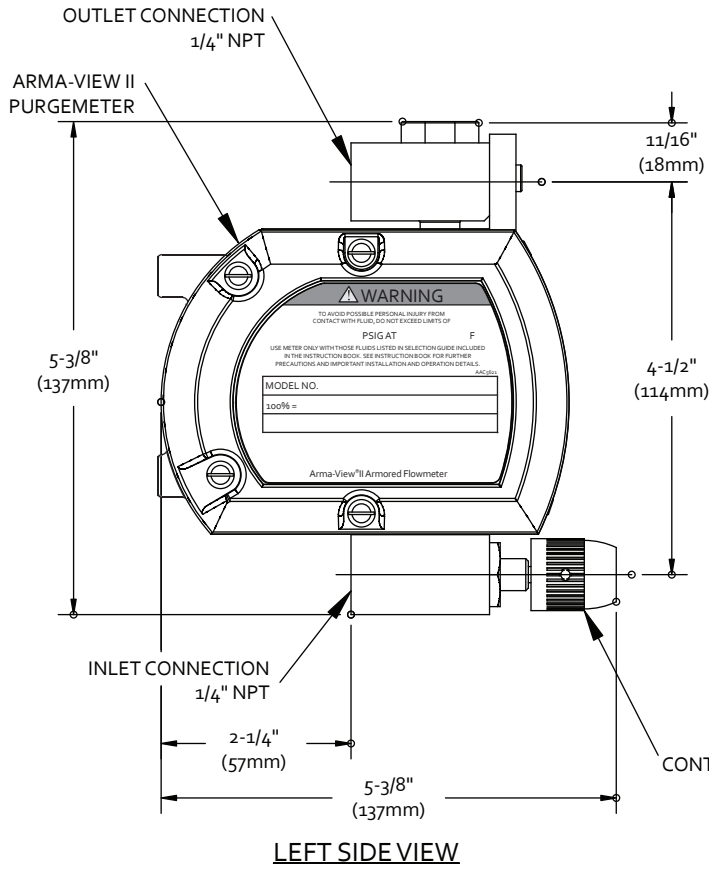

NOTE:  
[A] ACCESSORY ITEM FURNISHED ONLY IF SPECIFICALLY LISTED  
IN QUOTATION AND AS CHECKED ON THIS DRAWING.

**UGSI Chemical Feed, Inc.**  
a Cleanwater1 company

Vineland, NJ 08360  
856.896.2160 phone

info@cleanwater1.com  
www.cleanwater1.com

Dimensions  
CF.510.260.106.CN.0723