

Armored Purge Meter With Flow Switch

UGSI CHEMICAL FEED

A cleanwater1 Company

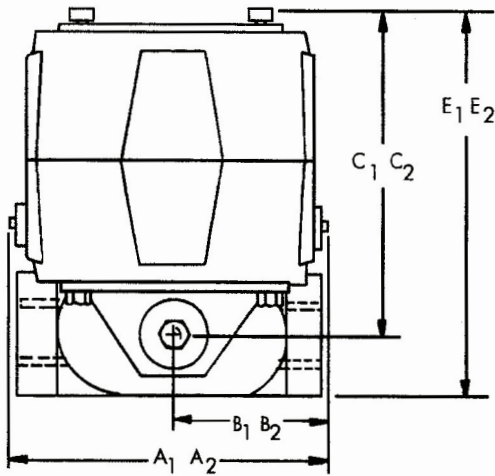

TOP VIEW
3/4" SIZE

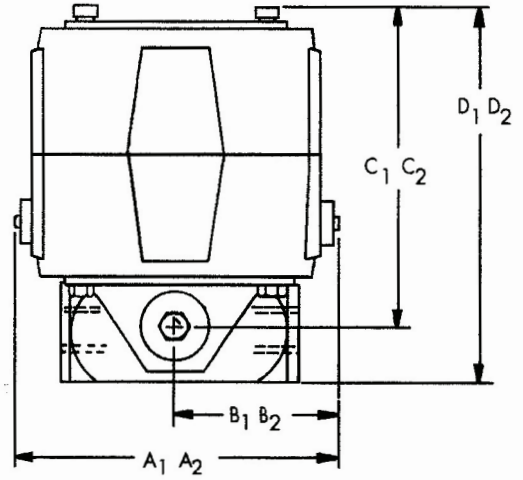

TOP VIEW
1/2" SIZE

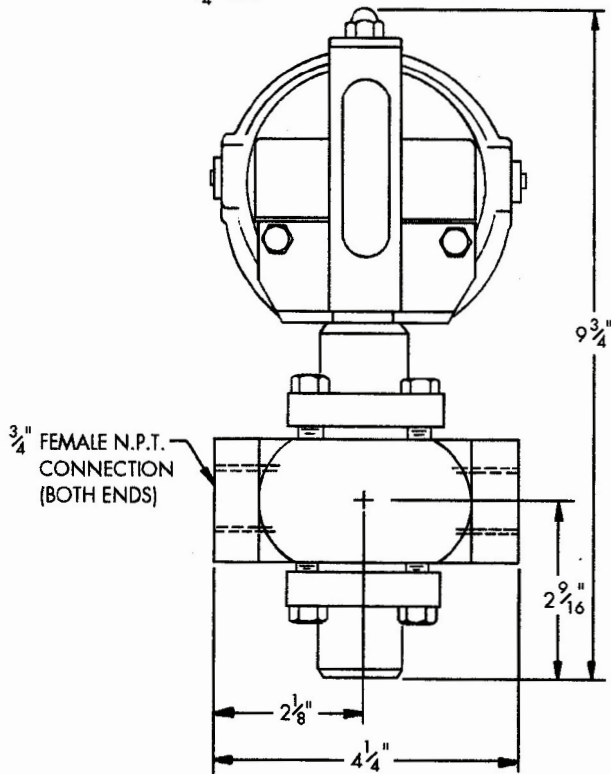

FRONT VIEW
3/4" SIZE

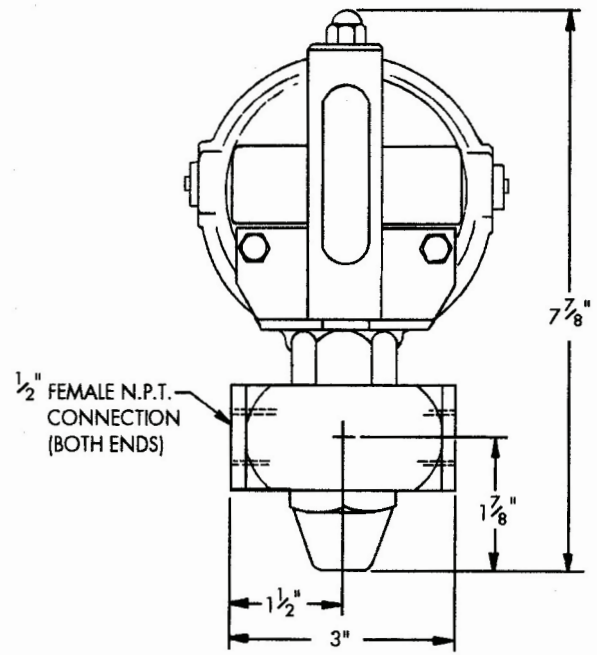

FRONT VIEW
1/2" SIZE

A ₁	A ₂	B ₁	B ₂	C ₁	C ₂	D ₁	D ₂	E ₁	E ₂
4 3/8"	5 5/8"	2 3/16"	2 13/16"	5 1/4"	5 1/4"	6"	6"	6 3/8"	6 1/8"

A₁, B₁, C₁, D₁, E₁ - SERIES 5600 GENERAL PURPOSE FLOW SWITCH
 A₂, B₂, C₂, D₂, E₂ - SERIES 5500 HAZARDOUS LOCATION FLOW SWITCH

UGSI Chemical Feed, Inc.
 a Cleanwater1 company

Vineland, NJ 08360
 856.896.2160 phone

info@cleanwater1.com
 www.cleanwater1.com

Dimensions
 CF.510.200.102.CN.0723