

Small Bag System

Reduce Operator Handling of Dry Materials

General

The VeloDyne Small Bag System is designed to handle, store and meter dry chemical into a mix tank or wetting cone. Chemical solution or slurry is delivered to the point of application by gravity, educator, or metering pumps. Each Small Bag System is engineered to meet the material conditioning requirements and product flow characteristics.

The VeloDyne Small Bag System is designed for small to medium chemical feed rate applications.

Options

- Hoppers designed for 50# bags or 330# drums
- Hopper extensions (1, 3.5, 5 CF)
- 316 Stainless steel construction
- Loss-in-weight feed of chemical
- Solution of slurry delivery pump systems

Bag Unloading Options



Horizontal Bag Unloader
with Dust Collector



Vertical Bag Unloader

Key Features

- *Barracuda volumetric feeder with overwind & hopper vibrator material conditioning (see Barracuda brochure for feed rate options)*
- *Mix tank or wetting cone with dilution water control system*
- *Batch level control, direct feed flow-through over-flow or metered control options*
- *Stainless steel construction (304 standard)*



(Mix Tank System Shown without
Control Panel)

Small Bag System Dimensions – Typical Layouts (subject to change)

Mix Tank System – 50 Gallon (without control panel, with horizontal bag unloader)

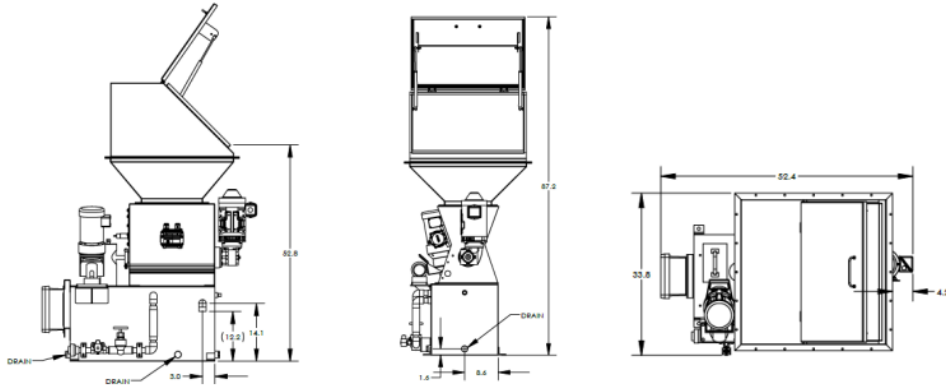

Mix Tank System – 50 Gallon (with integral control panel & vertical bag unloader)

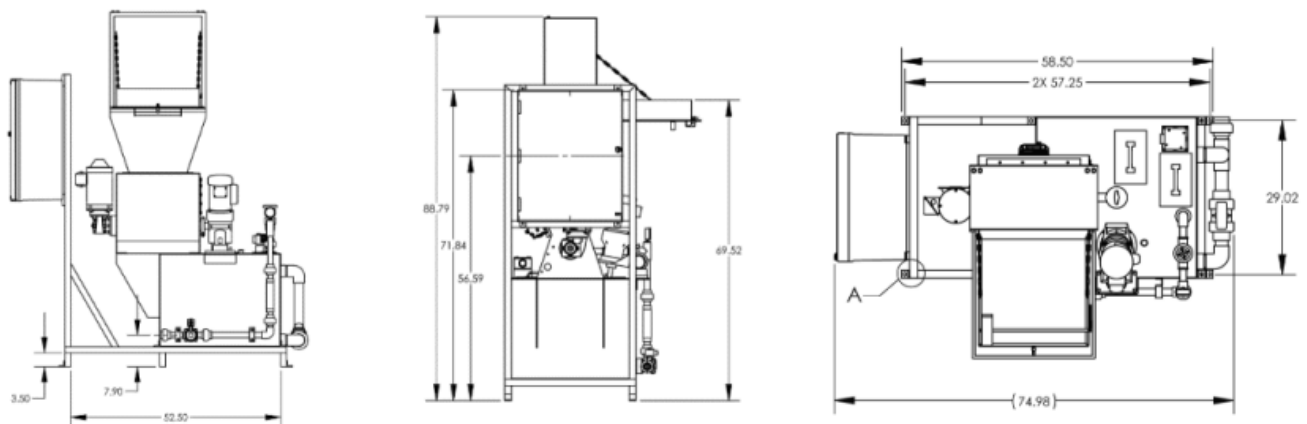

Wetting Cone System (with integral control panel & 300# drum adapter)

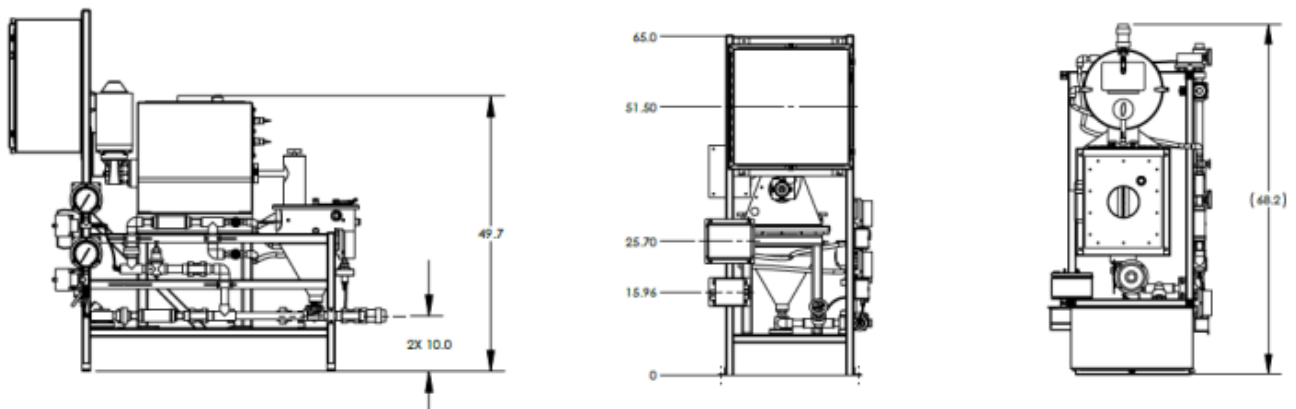



cleanwater1

543 S. Pierce Avenue | Louisville, CO 80027

Tel: 303.530.3298 | Email: sales@velodynesystems.com

cleanwater1.com

© 2024 Cleanwater1, Inc. Subject to change without prior notice.

The information provided in this literature contains merely general descriptions or characteristics of performance which in actual case of use do not always apply as described or which may change as a result of further development of the products. An obligation to provide the respective characteristics shall only exist if expressly agreed in the terms of a written contract.