

Flow Measurement Equipment Arma-View® II Low Flow Armored Purge Meters

The Arma-View® II type armored purge meter is part of the line of flow measurement equipment. It is designed for the measurement of low volume flows of aggressive chemicals. The strong meter construction provides reliable metering of gases and liquids at high pressure and temperature ratings.

Features

Easy Readability

State-of-the-art technology in a variable-area design provides easy visual readout. Standard scale calibrations are 0-100% or GPH.

True Magnetic Coupling

A powerful magnet encapsulated in the float forms a linkage with the follower magnets of the indicating mechanism. The indicator finds correct position in relationship to the float. Intelligent coupling between the float and follower prevent separation if sudden flow surges occur. Variations in flow are indicated on the calibrated scale.

Versatility and Convenience

Inlet and outlet connections are horizontally oriented. An optional inlet control valve provides smooth manual control of flow rate. The characterized valve stem helps assure dependable control.

Rugged Construction

The meter body is 316L stainless steel unibody construction. Except for O-rings and stop spring, all wetted parts, tube, float, and valve stem are 316L stainless steel. Viton® O-rings are the standard O-rings used. Kalrez® O-rings are also available. The indicating mechanism is housed in an epoxy powder-coated, NEMA-4 housing.

Key Benefits

- *Reliable low flow metering of gases or liquid at pressures to 1500 PSI and temperatures to 400° F*
- *Remote indication of flow rate via an optional 4-20mA electronic transmitter.*
- *Precise flow rate control via an optional characterized control valve*
- *FM approved configuration for hazardous areas*
- *Optional flow controllers to maintain constant flow even with pressure variations*



Arma-View® II Low Flow Armored Purge Meter

Optional Accessories

Versatile Flow Controller

An optional purge type flow controller is available. It is designed for the control of low-volume flows of aggressive chemicals in systems with varying pressures. This maintains constant flow regardless of pressure variations. The controller is offered in 316 SS construction, for inlet or outlet configurations. It can be assembled to the meter or as a stand alone in the process line. Controllers are available in standard and high-pressure versions. See literature number CF.570.100.000.UA.PS for additional information.

Maximum pressure:

350 PSIG standard version; 1000 PSIG high-pressure version

Maximum differential:

300 PSI between inlet / outlet pressures

Minimum pressure required:

6 PSIG for low and medium flow; 9 PSIG for high flow

Connection inlet/outlet:

1/4-inch NPT at 90° angle

Electronic Transmitter

An optional FM-approved explosion-proof transmitter provides accurate magnet angle detection to a 4-20mA industry standard analog output signal. Design features include Smart, microprocessor-based 2-wire 8-28Vdc field transmitter, microprocessor-controlled gain, adjustable low-cutoff, lowpass filter, electronics designed to meet CE requirements, and PC interface with no external power required. Eleven-point calibration provides linearization and storage in non-volatile memory and provides accuracy better than 0.5%.

Technical Data

Accuracy

Standard $\pm 5\%$ of full scale

Optional $\pm 3\%$ of full scale

Range

10:1

Pipe Connections

Horizontal 1/4" NPT at meter inlet and outlet.

Mounting

Suitable for in-line mounting.

Calibration

Standard scale calibrations are 0-100% or GPH water. The scale length is 3 inches.

Pressure and Temperature Limits

Meter with or without valve: 1500 PSI and fluid temp. of 400° F*

Meter with flow controller: 350 PSI and Fluid Temp. 300° F*

*With proper O-ring material.

Temperature and pressure limits must not be exceeded under any conditions.

Shipping Weights

Meter only: 5 lbs

Meter with control valve: 5 lbs

Meter with a controller: 10 lbs

Dimensions

See CF.510.350.100.CN through CF.510.350.106.CN

Selection Procedure

Selection Code

5 1 3 5 M 1 2 3 X 4 X 5 6 7
 Capacity Valve O Ring Controller Scale Tag Transmitter

Selection 1 - Capacity

CODE	Liquid Service		Gas Service	
	Size	GPH	LPH	SCFH
01	0.38	1.4	2.1	1
02	0.8	3	4.5	2.1
03	2.1	8	11.7	5.5
04	5	19	23.4	11
05	11	42	53.2	25
06	25	95	117	55

Selection 5 - Scale Calibration

Code	Description
D	Standard % Air
B	Special Gas
U	Standard (GPH) Water
P	Standard % Water
I	Special Liquid

Selection 2 - VALVE SELECTION (always "X" w/controller)

Code	Valve Selection
X	No valve
2	Inlet Valve

Selection 6 - Tag

Code	Material
X	None
1	Stainless Steel (wire on)

Selection 3 - O RING MATERIAL (TFE not available with valve or controller)

Code	Material
V	Viton® (Standard)
T	TFE
K	Kalrez®

Selection 7 - Transmitter

Code	Material
X	NONE
6	Transmitter Haz Area

Selection 4 - Controller

Code	Description
X	None
I	Inlet * max. pressure 350 PSIG
O	Outlet * max pressure 350 PSIG
H	Inlet * max pressure 1000 PSIG
P	Outlet * max pressure 1000 PSIG

- Cannot have control valve on meter when selecting a controller*, Valve will always be on controller

NOTE: If a Controller has been selected please complete this next area with the selection for Controller information.

If "NO Controller" Skip balance of Section 4 and continue on to Selection 5

Section 4 Controller information - only required if controller is selected

Selection
 C O N T 1 2 3
 Capacity O Ring Orientation

Code	Capacity - 1
01	0.38 GPH/2.1 SCFH
02	0.8 GPH/4.5 SCFH
03	2.1 GPH/11.7 SCFH
04	5 GPH/ 23.4 SCFH
05	11 GPH/53.2 SCFH
06	25 GPH/117 SCFH

Code	O Ring - 2
V	Viton
B	BUNA-N
E	EPR
K	Kalrez 4079

Code	Orientation - 3
I	Inlet < 350 PSIG
O	Outlet < 350 PSIG
H	Inlet > 350 PSIG
P	Outlet > 350 PSIG

USE THE INFORMATION PROVIDED TO SELECT THE CORRECT MODEL NUMBER.

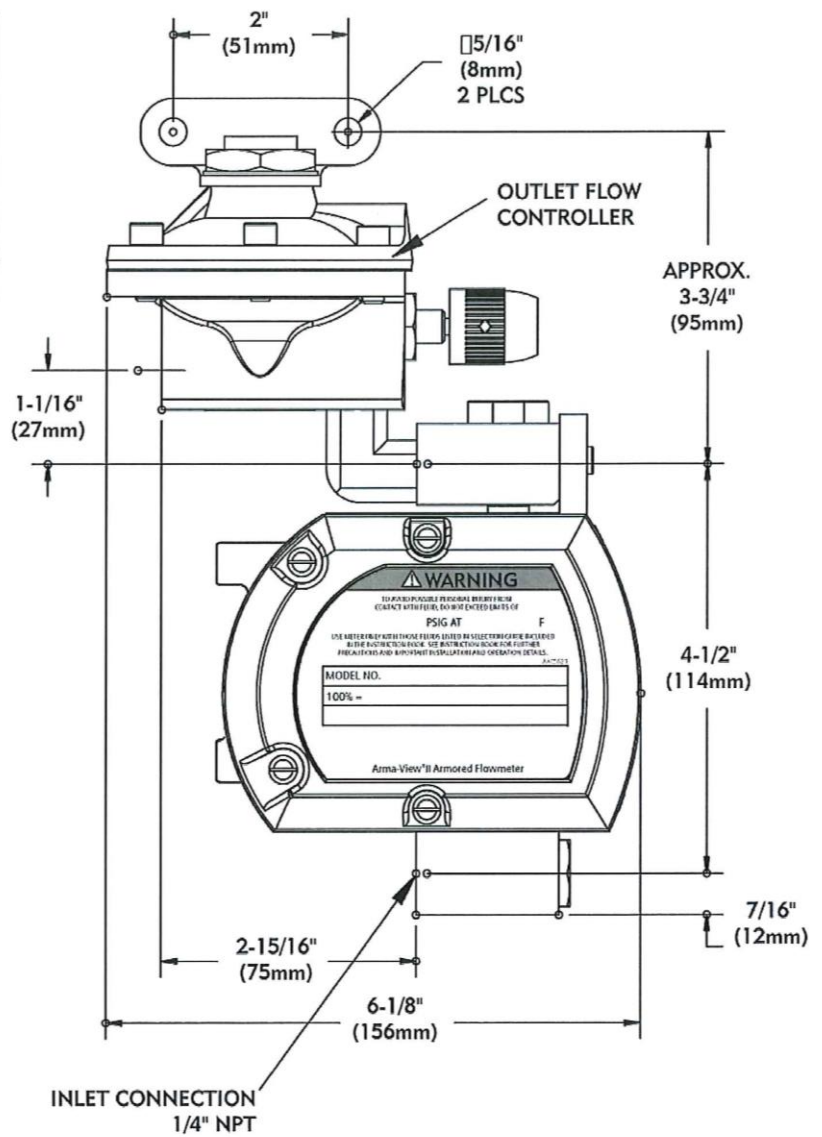
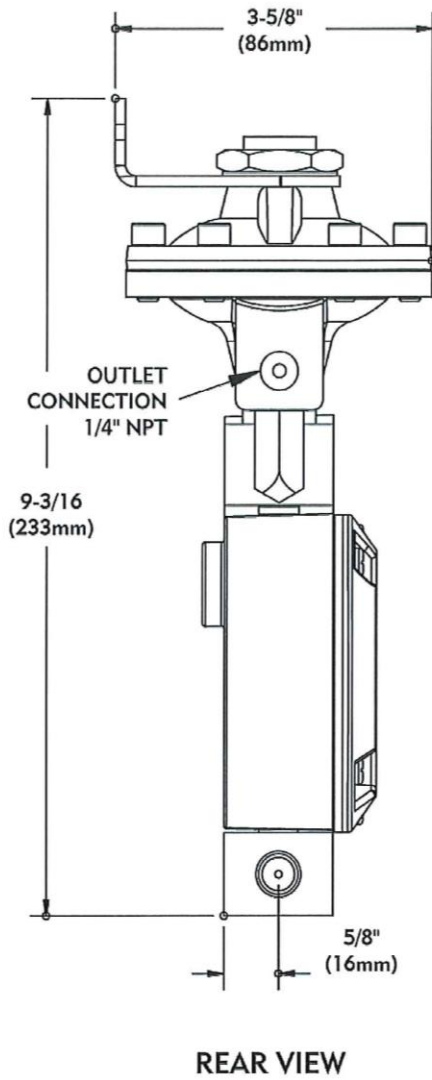

WITH INLET FLOW CONTROLLER



cleanwater1

1901 West Garden Road | Vineland, NJ 08360

Tel: 856.896.2160 | Email: info@cleanwater1.com

cleanwater1.com

© 2023 cleanwater1, inc. Subject to change without prior notice.

The information provided in this literature contains merely general descriptions or characteristics of performance which in actual case of use do not always apply as described or which may change as a result of further development of the products. An obligation to provide the respective characteristics shall only exist if expressly agreed in the terms of a written contract.