

Polyblend® Dry Polymer Feed System Model DP105-TP

The Polyblend® DP105-TP is a low cost, automated dry polymer feed system designed for applications that require less than *3.3 lbs/hr dry polymer. The DP105-TP is ideal where maximum polymer performance and simplicity is needed.

The design, which is patented in the U.S., includes a rotating impeller that allows the water to be drawn in from the top of the tank creating a vortex. The vortex carries the dry polymer into the mixing impeller where it is exposed to a high energy agitation. The high energy ensures proper activation and prevents agglomeration.

The prepared polymer solution is then ready to be fed in applications requiring batch feed, or the solution can be transferred into a feed tank for applications requiring continuous polymer feed.

The DP105-TP offers optimum polymer performance with an economical advantage.

Specifications

Electrical	240 VAC, 1 ph, 60 Hz 460 VAC, 3 ph, 60 Hz
Connections	Water inlet - 25.4 mm (1") Solution outlet - 38.1mm (1-1/2")
Tank Size	283.5 L (75 USG)
* Polymer Feed	Up to 1.5 kg (3.3 lbs)/hr dry polymer @ 0.25%, 30 minute batch cycles
Mixer Motor	240 VAC, 1-1/2 hp, 1 ph 460 VAC, 1-1/2 hp, 3 ph
Tank Cover	Fire retardant, Fiberglass
Control Panel	NEMA 4X FRP

*Note: Consult UGSI Chemical Feed, Inc. with regards to dosing amount and your application

Key Benefits

- *Consistent and reliable performance*
- *Reduced polymer consumption*
- *Automate operation and control*
- *Economical*
- *Reduced operating labor*
- *Field proven*
- *Easy to use*
- *Compact design*



General Layout

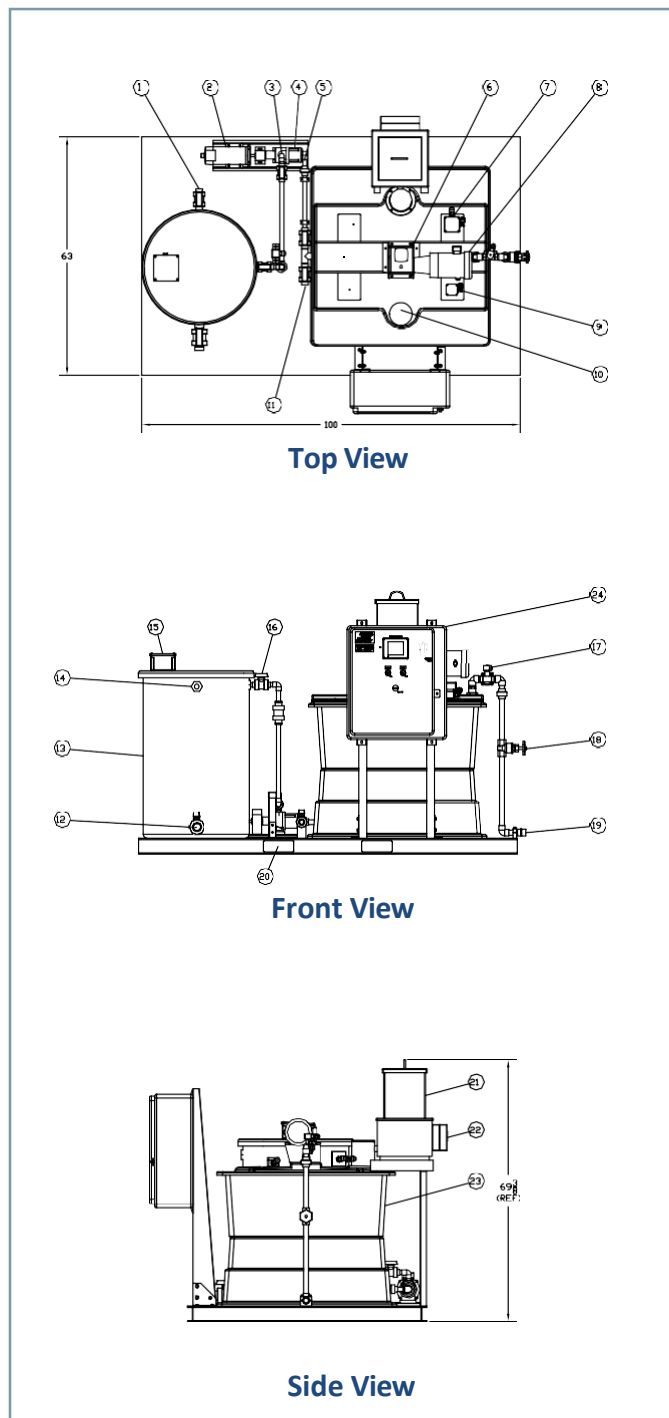

Key	Description	Material
1	Drain Hold Tank, 25.4 mm (1") FNPT	SCH 80 PVC
2	Motor Progressive Cavity Pump, 1/2 HP	
3	Discharge Progressive Cavity Pump, 19.05 mm (3/4")	SCH 80 PVC
4	Progressive Cavity Pump, 57 LPM (15 GPM)	
5	Inlet Progressive Pump, 25.4 mm (1")	SCH 80 PVC
6	Speed Reducer, Worm Gear, 15:1	Cast Iron
7	Level Control Switch Assembly, Probes	
8	Motor, Tank Mixer, 1.5 HP, 1750 RPM	Washdown Duty
9	Overflow, Switch Assembly, Float	
10	View Port	Acrylic
11	Drain, Mix Tank, 19.05 mm (3/4")	SCH 80 PVC
12	Discharge, Hold Tank, 38.1 mm (1-1/2")	SCH 80 PVC
13	Hold Tank, 378 L (100 G)	Poly
14	Overflow, Hold Tank, 19.05 mm (3/4")	SCH 80 PVC
15	Level Switch Assembly, Hold Tank, Floats	
16	Inlet, Hold Tank, 19.05 mm (3/4")	SCH 80 PVC
17	Solenoid, Water Inlet	Brass
18	Flow Control Globe Valve, 25.4 mm (1")	SCH 80 PVC
19	Water Inlet, 25.4 mm (1")	SCH 80 PVC
20	Skid, with Fork Truck Access, 2540 X 1600 mm (100" x 63")	304 SS
21	Hopper, 0.03 cu/m (1 cu/ft)	304 SS
22	Feeder, with Speed Control Panel	304 SS
23	Mix Tank, 384 L (75 Working Gallons)	FRP
24	System Control Panel, NEMA 4X	FRP

cleanwater1

1901 West Garden Road | Vineland, NJ 08360

Tel: 856.896.2160 | Email: info@cleanwater1.com

cleanwater1.com

The information provided in this literature contains merely general descriptions or characteristics of performance which in actual case of use do not always apply as described or which may change as a result of further development of the products. An obligation to provide the respective characteristics shall only exist if expressly agreed in the terms of a written contract.