

Dry Feed Systems Series 32-050 Volumetric Screw- Type Feeder

The Series 32-055 Volumetric Screw Type Feeder is designed to give reliable service feeding various water and wastewater chemicals, such as Alum, Lime and Ferric Sulfate, as well as industrial chemicals, such as citric acid, flour, plastic pellets. Capacity is 0.03 to 50 cu ft per hour. The operating range is 20:1 which extendable to 60 to 1 by belt position and a four-step pulley.

Key Benefits

- *Dependable & reliable feeding*
- *Economical feeder installation*
- *Easy to service and maintain*
- *Convenient feed rate control*

Operation of the feed screw is controlled by a manually set timer. the timer switch closure activates an induction motor, which drives the feed screw for any set portion of a 1-minute feed cycle. Speed is reduced by a worm and worm wheel in the gear box. The gear box has a slip clutch to protect the motor.

The drive mechanism is enclosed to comply with OSHA safety requirements for rotating machinery. The control components are housed in a NEMA 1 enclosure for mounting at or remote to the feeder. The feed screw gives single-ended delivery to a solution tank or process at a conform rate via a down spout.

Features

Corrosion Resistant

Standard materials resist such corrosive chemicals as alum and ferric sulfate. The feed screw, discharge spout, and hopper-bottom trough are stainless steel. The hopper and base are molded fiber glass. In the arrangement with hopper-wall agitation, the agitators are sealed behind Buna N diaphragms. Thus, the feeder is designed to handle many difficult chemicals.

Rugger Design

This durable feeder features design simplicity: a standard induction motor, simple worm and worm wheel gearbox with few moving parts, and percent-timer control. The gearbox has a slip clutch to protect the motor. The series 32-050 does a reliable feeding job at low cost yet is designed for minimum maintenance.

Hopper-Agitation Arrangement

An arrangement with hopper agitation is designed to give reliable feeding of materials which tend to arch, cake, or pack.

Convenient Feed Rate Control

A manual timer with one-minute cycle (72-second cycle at 50 Hz) permits setting feed rate with the feeder running. Included are a power on-off switch and a power-on light. An external switch can be added for start-stop control by pulse duration or other signals.

Wide Feed Range Selection

Operating range is 20:1 by timer setting. This can be extended to as high as 60:1 by changing the belt position on the 3:1 ratio, 4-step motor-drive pulley. This capability, and the four different feed screw sizes, provide a wide range of capacities between 0.03 and 50 cubic feet per hour.



Economical Feeder Installations

A variety of optional accessories provide custom feeder installations with economy. The feeder is available alone, mounted on a solution tank, or mounted on a stand beside the tank. The feeder can be scale-mounted with a loss-of-weight recorder added. Solution tanks can be 35-gallon fiber glass or stainless steel. A float valve, dust arrester, and mechanical mixer can be added to the tanks. A complete line of hopping components includes bag loaders, dust collectors, and hoppers in many styles and sizes along with accessories and installation hardware. The feeder hopper is designed to support up to 1000 lb.

Operation

The motor, gearbox, and hopper assembly are on a rectangular fiber glass base. Hopper capacity is 1.6 cubic feet. The base permits the feeder to be mounted on an optional stand beside the 35 gallon solution tanks, or on top of the 35 gallon tank.

Chemicals to be fed are placed in the hopper through the top. It settles to the bottom by gravity. An arrangement with vibrating plates in the hopper walls provides constant agitation. Agitation extends to the feed screw (hopper bottom) and is designed to prevent arching and packing. It helps maintain uniform delivery to the helical feed screw.

The motor has a 4-step pulley for easy capacity change. Feed screws come in 3/4, 1-1/2, 2-1/2-, or 4-inch sizes for wide range of capacities. An eccentric on the feed-screw shaft drives a rocker arm connected to the vibrating plates in the hopper walls. The plates are sealed behind Buna N covers. The agitator drive is easily disconnected by the user.

Optional Accessories

Solution Tanks

Can be cylindrical rectangular 35 gallon fiber glass or stainless steel. These tanks have overflow, drain, and discharge connections and a submerged triple-jet mixer. Where additional mixing is required, a mechanical mixer can be added. Also supplied (depending on feeder-tank arrangement) are feeder-tank mounting plate and hardware; inspection cover; feeder downspout and adapter for side mounting of tank.

Float valve

Plastic or brass float valves for automatic tank filling in 6 or 30 gpm capacities.

Dust Arrester

Water-spray operated dust and fume arrester for mounting on solution tank.

Mechanical Mixer

Available for mounting on both solution tanks; stainless steel shaft and impeller. See technical data for motor characteristics.

Stands

Rugged metal stands for floor mounting of the feeder or for mounting beside solution tank. Stands come in models which support 1000 lb or 3000 lb.

Scales

Feeder can be equipped with a 1000 lb portable beam scale. Feeder with hopper and stand are mounted on the scale platform. After initial tare weight adjustment, only the material in the hopper is weighed. Any feeder (except arrangement with 4-inch feed screw) can be scale-mounted for side delivery to solution tank.

Loss-of-Weight Recorder and Scale

This option provides a permanent, graphic record of material consumed by recording loss weight on a low 748 scale and loss of weight recorder. It has a calibration accuracy of 0.05% of full scale and can be supplied with circular charts for 100, 150, 200, 250, 300, 400, 500, or 600 lb per 25 hours or 7 days. Relay contacts are provided to operate a signal light or audible alarm to indicate when material is depleted.

Hoppering Systems

Optional hoppering components are available to meet almost any installation requirement. These include converging, loading, extension, and storage hoppers in square or cylindrical shapes and a variety of sizes.

They also offer a choice of floor-suspended or feeder (hopper) supported configurations. Dust collectors are available in a variety of sizes, floor-mounted or feeder supported. Bag loaders are available in 1 or 2 bag models. Hopper accessories include screens, covers, shut-off gates, flexible connections, floor plates, and installation hardware. A plate adapts dust collectors and bag loaders to cylindrical hoppers or various diameters. (2, 3, or 4 ft).

Hopper-Level Switch

Switch built into the hopper provides indication when hopper supply is low. At a predetermined hopper level, switch will open or close a contact that can actuate an alarm or a control device. The hopper low-level setting is established via a simple manual adjustment and can be easily changed. This capability for sensing different levels within the hopper provides greater control flexibility.

Technical Data

Accuracy

With uniform, free-flowing materials, accuracies of 1% to 2% of full scale can be achieved. It must be realized, however, that with material delivery controller on a basis of volume, many factors apply: material flowability, density at the feed screw, hopper size and shape are only a few of the factors which determine accuracy.

Operating Range

20:1 but extendable to 60:1 by changing belt position on the 3:1 ratio, 4-step drive pulley.

Maximum Volumetric Capacities (cu ft/hr)

Listed below are maximum nominal capacities that can be achieved by varying pulley-step and screw-size combinations. They are based on the maximum screw speed for each arrangement. Actual rates may vary depending on the characteristics of the material being fed, the chemical-handling system, size and shape of hoppers, and other factors that affect density and flowability.

4-Step Drive Pulley		Low Speed Gearbox Screw Size				High Speed Gearbox Screw Size			
Step	Ratio	3/4"			4"	3/4"			4"
1	12:1	0.03	0.2	1.0	2.5	0.10	0.8	4	10
2	8:1	0.04	0.3	1.5	3.7	0.16	1.2	6	15
3	5.3:1	0.06	0.45	2.2	5.7	0.24	1.8	9	22
4	4:1	0.08	0.6	3.0	7.5	0.32	2.4	12	30
4	2.7:1*	--	--	--	--	--	--	--	50

*Extended range drive pulley for volumetric rates above 30 cu. ft/hr.

To select the screw size for a particular application, consider both the volumetric and gravimetric feed rate limits:

1. Determine maximum gravimetric feed rate required in lb/hr.
2. Divide maximum gravimetric feed rate (lb/hr) by density of material (lb/cu ft) to determine maximum volumetric feed rate (cu ft/hr) required.
3. Select proper screw size from table.

Typical Maximum Feed Rates (lbs/hr)

The table below lists maximum feed rates with a high speed gear box and 4:1 drive-pulley ratio. For other ratios refer to the notes below. Rates are based on average density at the feed screw.

Feed Screw Size	3/4"	1-1/2"	2-1/2"	4"	4"***
Pulley Ratio	4:1	4:1	4:1	4:1	2.7:1
Aluminum Sulfate - granular (Alum), Density 68 lb/cu ft	21	168	750	2100	2135
Activated Carbon - powder, Density 21 lb/cu ft	6	40	243	*	*
Diatomaceous Earth, Density 20 lb/cu ft	*	28	153	468	*
Ferric Sulfate - granular, Density 64 lb/cu hr	22	154	725	1930	2914
Calcium Hydroxide (Lime) - powder, Density 26 lb/cu ft	6	45	334	990	1500
Sodium Carbonate (Soda Ash), Density 42 lb/cu ft	13	94	443	1157	1725

*Not recommended

** 4" feed screw with extended range drive pulley.

Note: For 12:1 ratio, divide feed rate by 3; For 8:1 ratio divides by 2; for 5.3 ratio divide by 1.3. To determine rates at low-speed gearbox, divide all rates by 4.

Feed Rate Adjustment

Feed rate is manually set on a timer. Further adjustments can be made by changing the belt position on the 4-step drive pulley. (Timer's full cycle is 60 seconds at 60 Hz, 72 seconds at 50 Hz.)

Automatic Control

An external switch can be added by the user for start-stop control of feed rate via a flow-proportional, pulse-duration signal, high-low set point of a level sensor, or similar input.

Materials of Construction

Upper hopper, fiber glass; hopper-wall agitators, Buna N; feed screw, hopper bottom, and discharge spout, stainless steel.

Hopper Capacity

1.6 cu ft; supports up to 1000 lb

Motors

Feeder: Continuous duty, 1/4 hp induction motor, 1725 rpm, 115 volt, 50 or 60 Hz, 4.5 amp. Optional mixer: 1/4 hp induction motor in choice of: 15/230 volt, 1 ph, 50 or 60 Hz or 220/440 volt, 3 ph, 50 or 60 Hz. A 1/20 hp, 115 volt, 1 ph, 50 or 60 Hz mixer motor is available for 25-gallon tank only.

Weight and Shipping Weight

210 lb and 280 lb.

Dimension Drawing

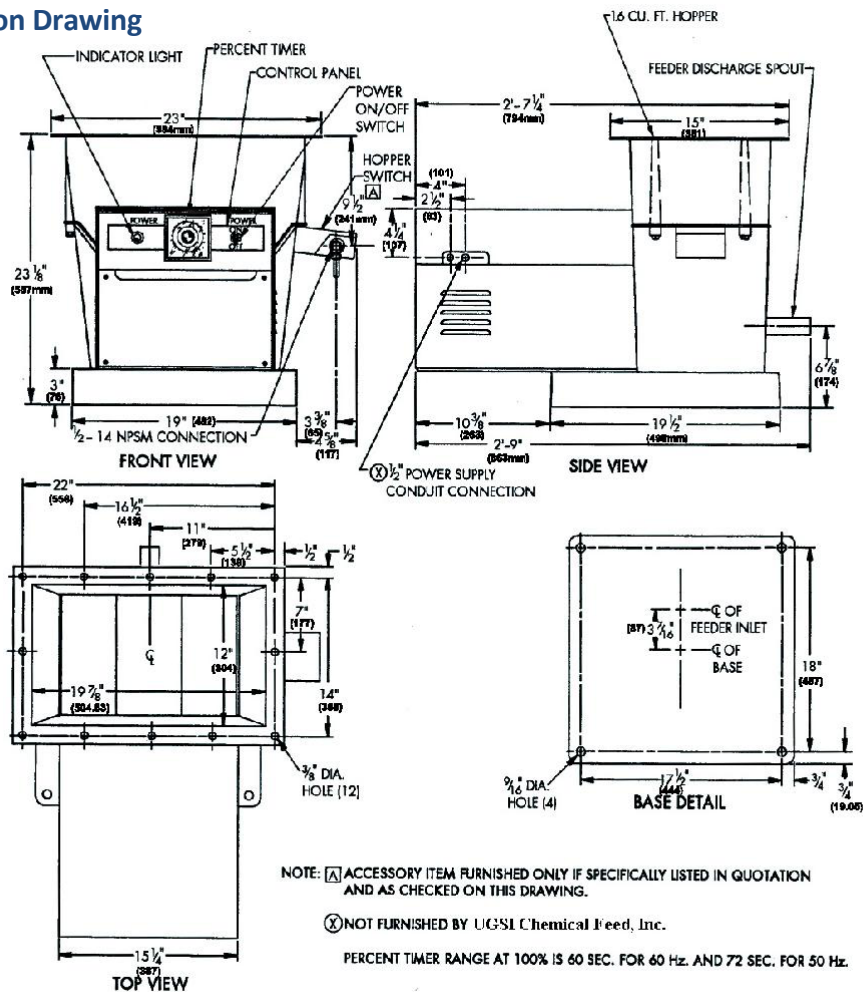

cleanwater1

1901 West Garden Road | Vineland, NJ 08360

Tel: 856.896.2160

Fax: 856.896.2166

Email: info@cleanwater1.com

cleanwater1.com

© 2023 cleanwater1 of UGSI Chemical Feed, Inc. Subject to change without prior notice.

Arma-View® II, Chemlocker® Reservoir Dosing Station, Chemtube®, Encore® Pump, Dynablend™, Dynajet™, Microclor® OSHG, Miniblend™, Monoclor® RCS, Neptune-Toolbox™, PAX TRS™THM Removal System, PAX WQS™, Polyblend®, PowerVent®, Smartboost®, Tank Shark®, Varea-Meter® are trademarks of cleanwater1 of UGSI Chemical Feed, Inc.

The information provided in this literature contains merely general descriptions or characteristics of performance which in actual case of use do not always apply as described or which may change as a result of further development of the products. An obligation to provide the respective characteristics shall only exist if expressly agreed in the terms of a written contract.