

BULK BAG SYSTEMS

REDUCE OPERATOR HANDLING OF DRY MATERIALS



SOLUTIONS THAT WORK



Bulk Bag Dimensions - Typical Layout

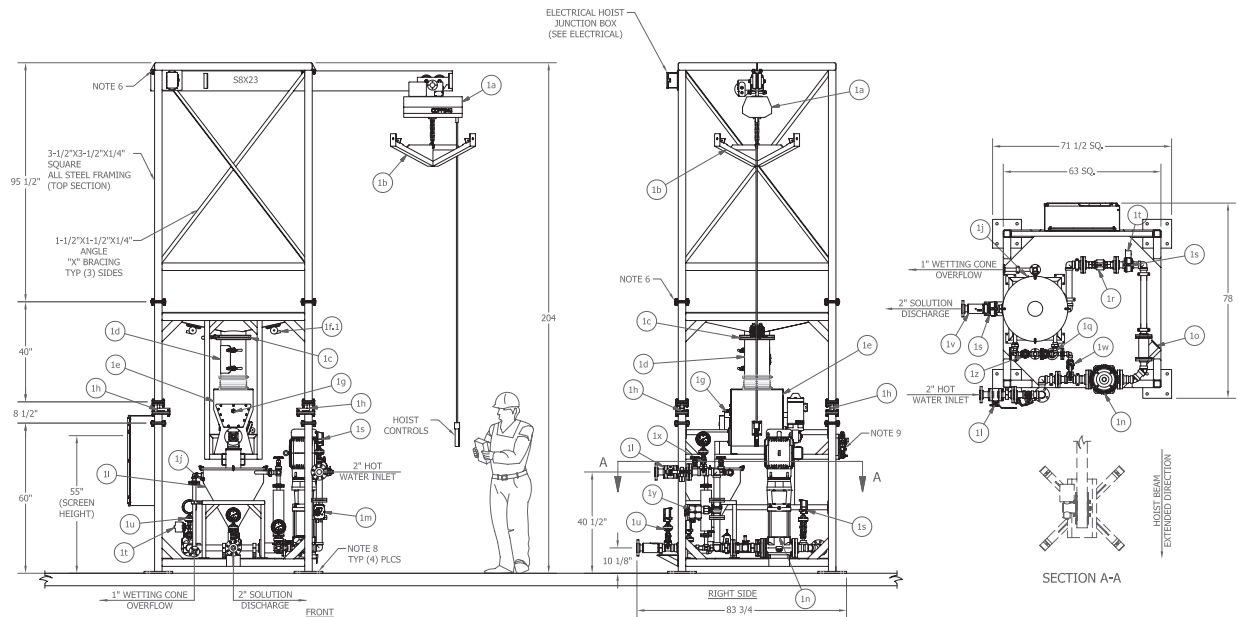

Features

- Motorized hoist & trolley or fork-lift loading
- Bag agitation system or Bag Pan
- Iris Valve
- Sealed bulk-bag untie box
- Storage hopper options
- Hopper level devices
- Volumetric screw feeder
- Optional loss-in-weight feed control
- Wetting cone or slurry make down/storage tank with mixer, and level devices
- Slurry feed pumps, if required
- All required piping and valves
- Optional load cells for inventory monitoring
- Local control system with programmable logic controller (PLC) including pre-programmed system logic
- Factory witness testing available upon request

VeloDyne Advantages

- Systems completely integrated into bulk-bag frame reducing installation time and commissioning
- Configurable design based on your specific requirements
- In-house fabrication = unsurpassed quality
- In-house engineering & programming
- Over thirty years of providing proven solutions

cleanwater₁



543 S. Pierce Avenue | Louisville, CO 80027

Tel: 303.530.3298

Email: sales@velodynesystems.com

cleanwater₁.com

The information provided in this literature contains merely general descriptions or characteristics of performance which in actual case of use do not always apply as described or which may change as a result of further development of the products. An obligation to provide the respective characteristics shall only exist if expressly agreed in the terms of a written contract.