

# VELODYNE

A cleanwater1® Company

## SMALL BAG SYSTEM REDUCE OPERATOR HANDLING OF DRY MATERIALS



Scan the QR code to visit our  
website for more information



## Standard Features

- Barracuda volumetric feeder with overwind & hopper vibrator material conditioning (see Barracuda brochure for feed rate options)
- Mix tank or wetting cone with dilution water control system
- Batch level control, direct feed flow-through over-flow or metered control options
- Stainless steel construction (304 standard)

## Options

- Hoppers designed for 50# bags or 330# drums
- Hopper extensions (1, 3.5, 5 CF)
- 316 Stainless steel construction
- Loss-in-weight feed of chemical
- Solution or slurry delivery pump systems

*Consult factory for custom chemical feed rates, tank capacities, hopper sizes, and unloading options available.*

## Bag Unloading Options



Vertical Bag Unloader



Horizontal Bag Unloader with Dust Collector

# Small Bag System Dimensions – Typical Layouts

(Subject To Change)

Mix Tank System – 50 Gallon (without control panel, with horizontal bag unloader)

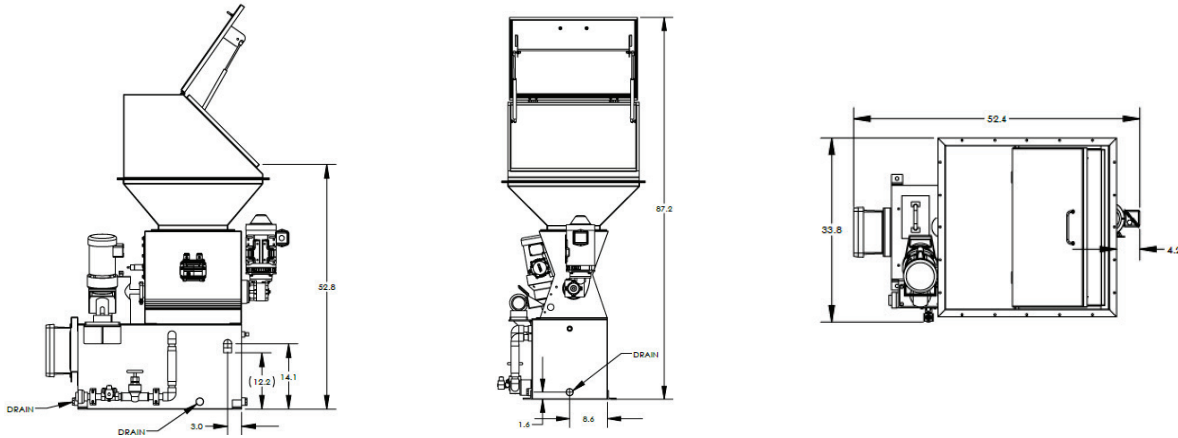

Mix Tank System – 50 Gallon (with integral control panel & vertical bag unloader)

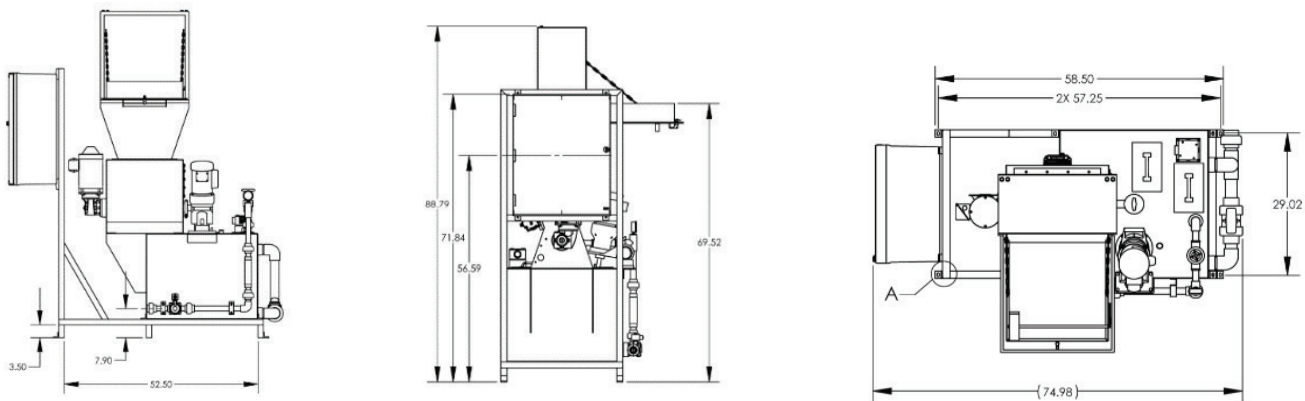

Wetting Cone System (with integral control panel & 330# drum adapter)

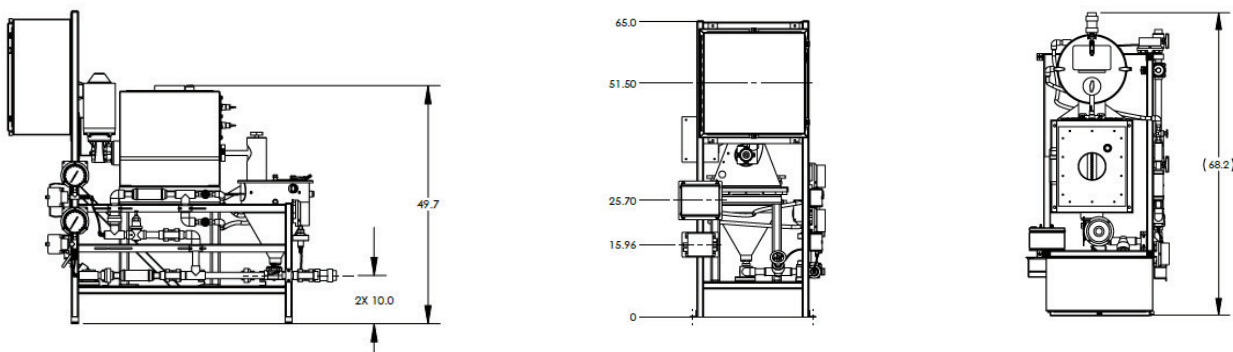

# Related Products

## Velodyne - Three Decades of Experience

For over thirty years our team has been dedicated to excellence. Through knowledge gained from thousands of installations worldwide, VeloDyne unites proven technologies with unsurpassed experience. Contact us to learn how our products and services can help optimize your treatment process.

## More Proven Solutions From Velodyne

Dry Polymer Activation



Auger Feeders & Conveyors



Manual Bag Systems



Liquid Chemical Metering & Feed Systems



Bulk-Bag Systems



Lime Slakers



Containerized Systems



Silo Systems



cleanwater1<sup>®</sup>

520 Courtney Way, Suite 110 | Lafayette, CO 80026

Tel: 303.530.3298

Email: [info@cleanwater1.com](mailto:info@cleanwater1.com)

[cleanwater1.com](http://cleanwater1.com)



The information provided in this literature contains merely general descriptions or characteristics of performance which in actual case of use do not always apply as described or which may change as a result of further development of the products. An obligation to provide the respective characteristics shall only exist if expressly agreed in the terms of a written contract.