

PWM400 MIXER

Powerful Active Mixer for Water Storage Tanks

The PAX Water Mixer (PWM400) is a powerful active mixer that improves water quality in water storage tanks. The mixer's unique impeller creates a powerful vortex flow pattern to thoroughly circulate the entire tank volume while using very little energy. PAX Water Mixers are easy to install and maintain— no heavy cranes, lifting equipment or tank alterations are required and the mixer can be easily lowered through the tank hatch or installed by a diver.

Benefits

- Eliminates thermal stratification
- Improves disinfectant residual levels
- Lowers DBPs and nitrifying bacteria
- Protects tank from ice damage and corrosion
- Reduces variability in water taste and odor

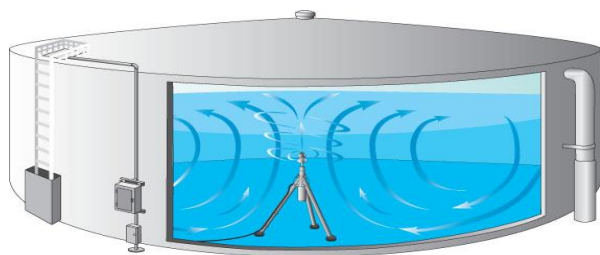

The PAX Water Mixer creates a powerful vortex flow pattern to thoroughly mix the entire tank volume.

PWM400 MIXER

MIXER SPECIFICATIONS		
Control Center Power Supply Requirement	120 VAC, 50/60 Hz, non-GFCI protected, 20 amp circuit	240 VAC, 50/60 Hz, non-GFCI protected, 20 amp circuit
Motor Type	230 VAC, ½ HP, water-filled, water-lubricated	
RPM	2100	
Nominal Power Draw	0.575 kVA (575 watts)	
Impeller Specifications	316 stainless steel, 6" (16 cm) tall x 3" (8 cm) diameter	
Footprint Diameter	3' 10" (117 cm)	
Height	3' 11" (119 cm)	
Weight: Mixer Assembly	53 lbs. (24 kg)	
Control Center Dimensions	55 lbs. (25 kg) (20" x 21" x 8" / 50 cm x 53 cm x 20 cm)	
Material: Control Center	Powder-coated carbon steel, Type 4 enclosure	
Material: Stand	316 stainless steel	
Material: Motor Seals	Chlorine/chloramine-resistant NBR rubber	
Material: Feet	Chlorine/chloramine-resistant EPDM rubber	
Wiring	NSF 61 & UL-listed submersible pump cable 14 AWG (2.1 mm ²) XLPE (.78" x .28" / 20 mm x 7 mm)	

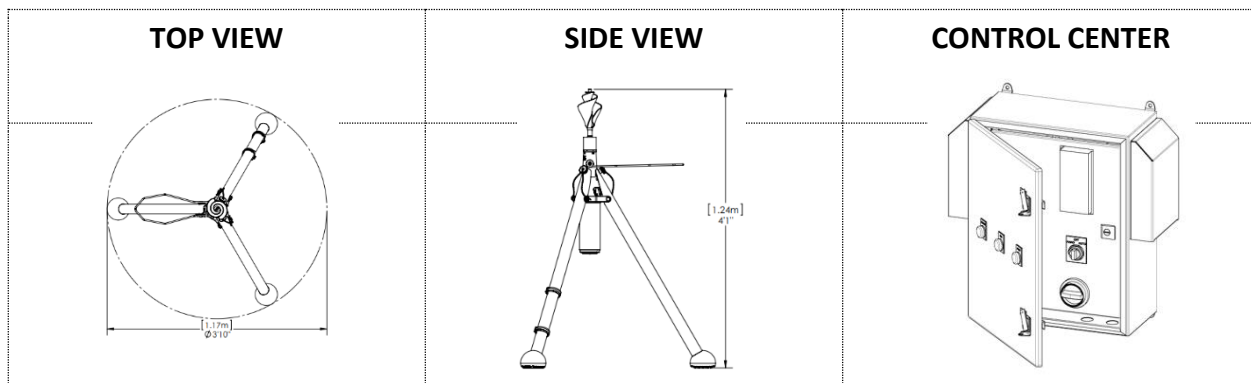

cleanwater1

550 Sycamore Drive | Milpitas, CA 95035

Tel: 858.218.3745 | Email: info@cleanwater1.com

cleanwater1.com

© 2023 cleanwater1, inc. Subject to change without prior notice.

The information provided in this literature contains merely general descriptions or characteristics of performance which in actual case of use do not always apply as described or which may change as a result of further development of the products. An obligation to provide the respective characteristics shall only exist if expressly agreed in the terms of a written contract.